

# PRODUCT INFORMATION PACKET

Model No: 449TTFS6564  
Catalog No: E856  
200,1800,TEFC,447/9T,3/60/575  
Severe Duty



Regal and Marathon are trademarks of Regal Beloit Corporation or one of its affiliated companies.  
©2018 Regal Beloit Corporation, All Rights Reserved. MC017097E





### Nameplate Specifications

Output HP	<b>200 Hp</b>	Output KW	<b>149.0 kW</b>
Frequency	<b>60 Hz</b>	Voltage	<b>575 V</b>
Current	<b>180.0 A</b>	Speed	<b>1785 rpm</b>
Service Factor	<b>1.15</b>	Phase	<b>3</b>
Efficiency	<b>96.5 %</b>	Duty	<b>Continuous</b>
Insulation Class	<b>H</b>	Design Code	<b>B</b>
KVA Code	<b>G</b>	Frame	<b>447/449T</b>
Enclosure	<b>Totally Enclosed Fan Cooled</b>	Overload Protector	<b>No</b>
Ambient Temperature	<b>40 °C</b>	Drive End Bearing Size	<b>NU319</b>
Opp Drive End Bearing Size	<b>6318</b>	UL	<b>Recognized</b>
CSA	<b>Y</b>	CE	<b>Y</b>
IP Code	<b>54</b>		

### Technical Specifications

Electrical Type	<b>Squirrel Cage Inverter Rated</b>	Starting Method	<b>Line Or Inverter</b>
Poles	<b>4</b>	Rotation	<b>Reversible</b>
Mounting	<b>Rigid base</b>	Motor Orientation	<b>Horizontal</b>
Drive End Bearing	<b>Roller</b>	Opp Drive End Bearing	<b>Ball</b>
Frame Material	<b>Cast Iron</b>	Shaft Type	<b>T</b>
Overall Length	<b>51.84 in</b>	Frame Length	<b>28.75 in</b>
Shaft Diameter	<b>3.375 in</b>	Shaft Extension	<b>8.81 in</b>
Assembly/Box Mounting	<b>F1/F2 Capable</b>		
Outline Drawing	<b>B-SS515631-2875</b>	Connection Diagram	<b>A-EE7300U</b>

This is an uncontrolled document once printed or downloaded and is subject to change without notice. Date Created: 06/29/2018

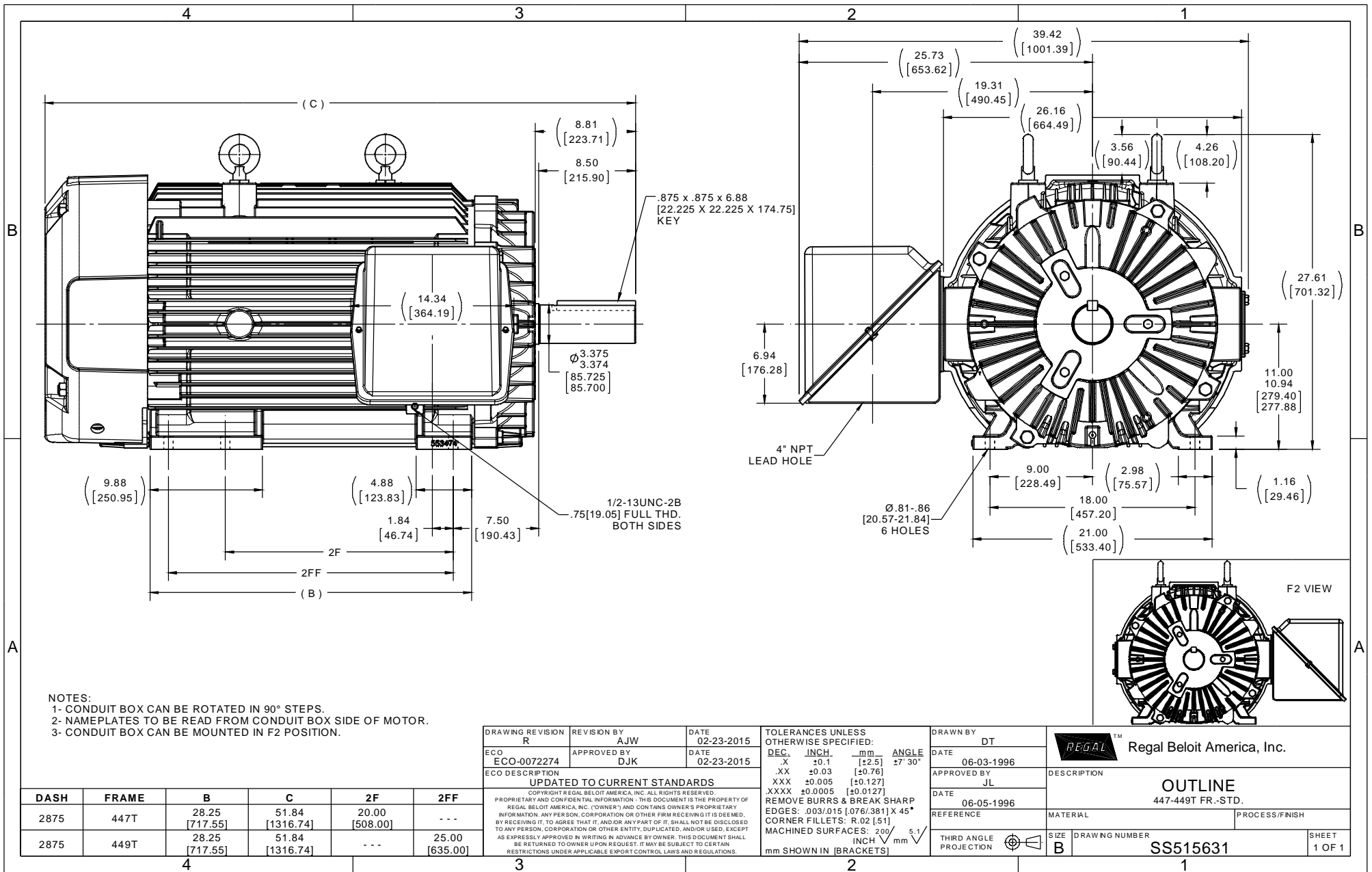

NOTES:  
 1- CONDUIT BOX CAN BE ROTATED IN 90° STEPS.  
 2- NAMEPLATES TO BE READ FROM CONDUIT BOX SIDE OF MOTOR.  
 3- CONDUIT BOX CAN BE MOUNTED IN F2 POSITION.

DASH	FRAME	B	C	2F	2FF
2875	447T	28.25 [717.55]	51.84 [1316.74]	20.00 [508.00]	---
2875	449T	28.25 [717.55]	51.84 [1316.74]	---	25.00 [635.00]

DRAWING REVISION	REVISION BY	DATE	TOLERANCES UNLESS OTHERWISE SPECIFIED:
R	AJW	02-23-2015	DEC. INCH. mm ANGLE
ECO-0072274	DJK	02-23-2015	.X ±0.1 [±2.5] 27° 30'
ECO DESCRIPTION			.XX ±0.03 [±0.76]
UPDATED TO CURRENT STANDARDS			XXX ±0.005 [±0.127]
COPYRIGHT REGAL BELOIT AMERICA, INC. ALL RIGHTS RESERVED.			XXXX ±0.0005 [±0.0127]
PROPRIETARY AND CONFIDENTIAL INFORMATION - THIS DOCUMENT IS THE PROPERTY OF REGAL BELOIT AMERICA, INC. (OWNER) AND CONTAINS OWNER'S PROPRIETARY INFORMATION. ANY PERSON, CORPORATION OR OTHER FIRM RECEIVING IT IS DEEMED, BY RECEIVING IT, TO AGREE THAT IT, AND/OR ANY PART OF IT, SHALL NOT BE DISCLOSED TO ANY PERSON, CORPORATION OR OTHER ENTITY, DUPLICATED, AND/OR USED, EXCEPT AS EXPRESSLY APPROVED IN WRITING IN ADVANCE BY OWNER. THIS DOCUMENT SHALL BE RETURNED TO OWNER UPON REQUEST. IT MAY BE SUBJECT TO CERTAIN RESTRICTIONS UNDER APPLICABLE EXPORT CONTROL LAWS AND REGULATIONS.			REMOVE BURRS & BREAK SHARP EDGES: .003/.015 [0.076/.381] X 45°
			CORNER FILLETS: R.02 [.51]
			MACHINED SURFACES: 200 / INCH mm 5.1
			mm SHOWN IN [BRACKETS]

DRAWN BY	DT	REGAL™	Regal Beloit America, Inc.
DATE	06-03-1996	DESCRIPTION	
APPROVED BY	JL		
DATE	06-05-1996	OUTLINE 447-449T FR.-STD.	
REFERENCE			
THIRD ANGLE PROJECTION	SIZE B	DRAWING NUMBER	SS515631
		PROCESS/FINISH	SHEET 1 OF 1

**IF MOTOR HAS 9 LEADS**

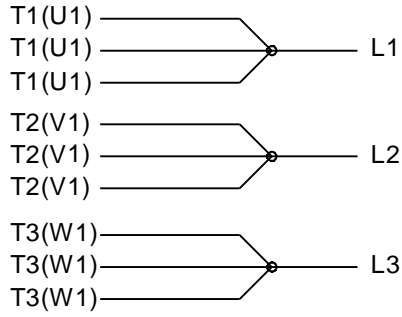

**IF MOTOR HAS 6 LEADS**

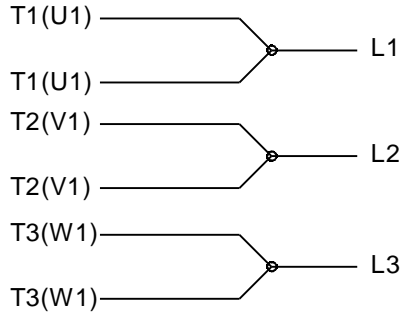

A-9806 DECAL IF CALLED FOR

**IF MOTOR HAS 12 LEADS**

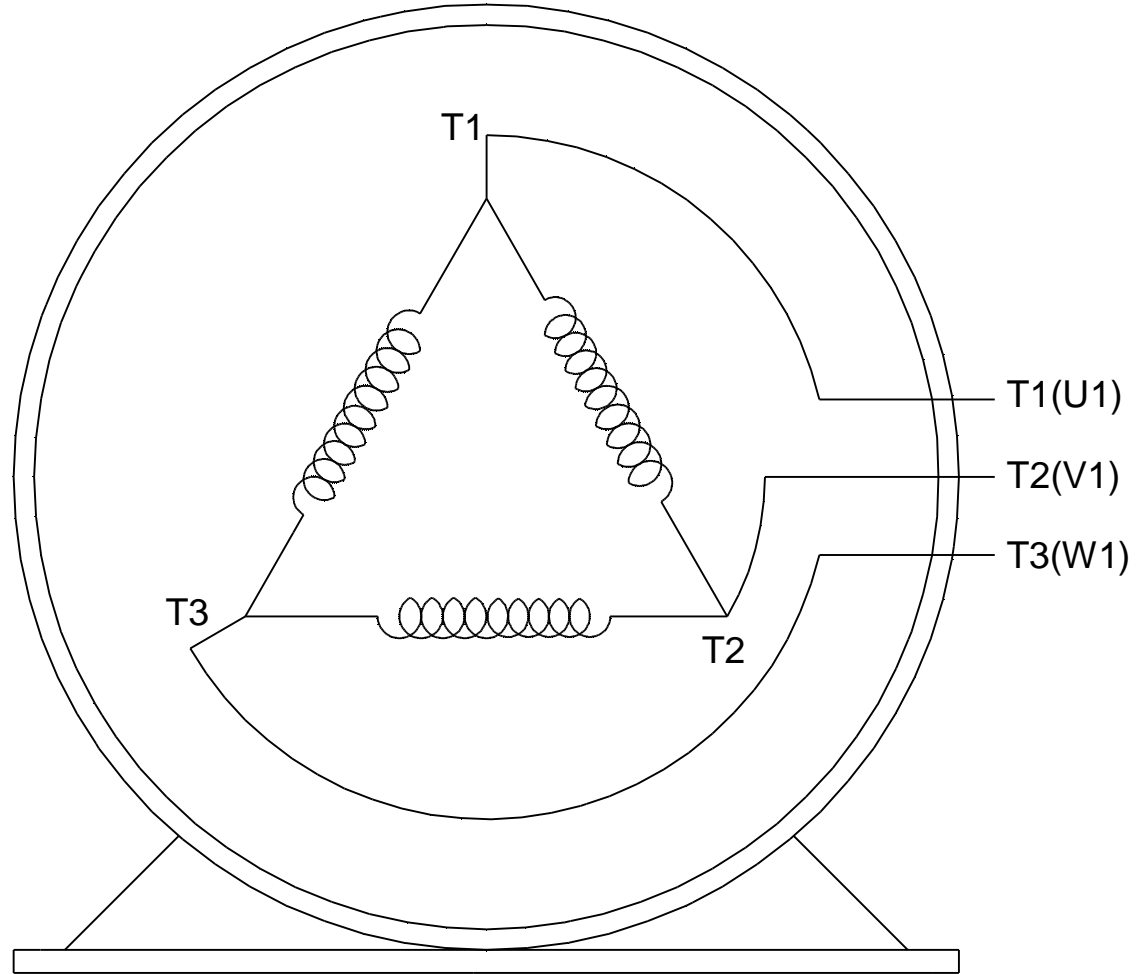

**VIEW OF TERMINAL END**

DRAWING REVISION <b>L</b>	REVISION BY <b>AJW</b>	DATE <b>05-04-2015</b>	TOLERANCES UNLESS OTHERWISE SPECIFIED:	DRAWN BY <b>DRS</b>	<b>Regal Beloit America, Inc.</b>																					
ECO <b>ECO-0077067</b>	APPROVED BY <b>EWH</b>	DATE <b>05-05-2015</b>	<table style="font-size: small; border-collapse: collapse;"> <tr> <td><u>DEC.</u></td> <td><u>INCH</u></td> <td><u>mm</u></td> <td><u>ANGLE</u></td> </tr> <tr> <td>.X</td> <td>±0.1</td> <td>[±2.5]</td> <td>±7° 30"</td> </tr> <tr> <td>.XX</td> <td>±0.02</td> <td>[±0.51]</td> <td></td> </tr> <tr> <td>.XXX</td> <td>±0.005</td> <td>[±0.127]</td> <td></td> </tr> <tr> <td>.XXXX</td> <td>±0.0005</td> <td>[±0.0127]</td> <td></td> </tr> </table>	<u>DEC.</u>			<u>INCH</u>	<u>mm</u>	<u>ANGLE</u>	.X	±0.1	[±2.5]	±7° 30"	.XX	±0.02	[±0.51]		.XXX	±0.005	[±0.127]		.XXXX	±0.0005	[±0.0127]		DATE <b>09-27-1996</b>
<u>DEC.</u>	<u>INCH</u>	<u>mm</u>	<u>ANGLE</u>																							
.X	±0.1	[±2.5]	±7° 30"																							
.XX	±0.02	[±0.51]																								
.XXX	±0.005	[±0.127]																								
.XXXX	±0.0005	[±0.0127]																								
ECO DESCRIPTION <b>UPDATED TO SOLIDWORKS</b>			REMOVE BURRS & BREAK SHARP EDGES: .003/.015 [.076/.381] X 45° CORNER FILLETS: R.02 [.51] MACHINED SURFACES: 200 INCH √ 5.1 mm √	APPROVED BY <b>GK</b>	MATERIAL	PROCESS/FINISH																				
COPYRIGHT REGAL BELOIT AMERICA, INC. ALL RIGHTS RESERVED. PROPRIETARY AND CONFIDENTIAL INFORMATION - THIS DOCUMENT IS THE PROPERTY OF REGAL BELOIT AMERICA, INC. ("OWNER") AND CONTAINS OWNER'S PROPRIETARY INFORMATION. ANY PERSON, CORPORATION OR OTHER FIRM RECEIVING IT IS DEEMED, BY RECEIVING IT, TO AGREE THAT IT, AND/OR ANY PART OF IT, SHALL NOT BE DISCLOSED TO ANY PERSON, CORPORATION OR OTHER ENTITY, DUPLICATED, AND/OR USED, EXCEPT AS EXPRESSLY APPROVED IN WRITING IN ADVANCE BY OWNER. THIS DOCUMENT SHALL BE RETURNED TO OWNER UPON REQUEST. IT MAY BE SUBJECT TO CERTAIN RESTRICTIONS UNDER APPLICABLE EXPORT CONTROL LAWS AND REGULATIONS.			mm SHOWN IN [BRACKETS]	DATE <b>09-30-1996</b>	SIZE <b>A</b>	DRAWING NUMBER <b>EE7300U</b>	SHEET <b>1 OF 1</b>																			
				THIRD ANGLE PROJECTION																						



Data Sheet

Date: 29-06-2017  
 Customer: \_\_\_\_\_  
 Attention: \_\_\_\_\_  
 Submitted by: FAREEDA DUDEKULA



449TFS6564

Submittal

Data @ 575 V

Motor Load Data									
Load	0%	25%	50%	75%	100%	115%	125%	LR	
Current (Amps)	52.8	68.0	100	138	180	206	224	1,160	
Torque (ft-lb)	0.00	146	293	440	588	677	736	1,100	
RPM	1800	1795	1792	1790	1785	1,782	1780	0	
Efficiency (%)		93.0	95.4	96.5	96.5	96.2	96.0		
P.F. (%)	5.5	60.0	78.5	84.0	86.0	86.5	86.5	30.0	

Motor Speed Data						Information Block	
	LR	Pull-Up	BD	Rated	Idle		
Speed (RPM)	0	900	1700	1785	1800	HP	200.0
Current (Amps)	1,160	1,044	600	180	52.8	Sync. RPM	1800
Torque (ft-lb)	1,100	990	1,425	588	0.00	Frame	449

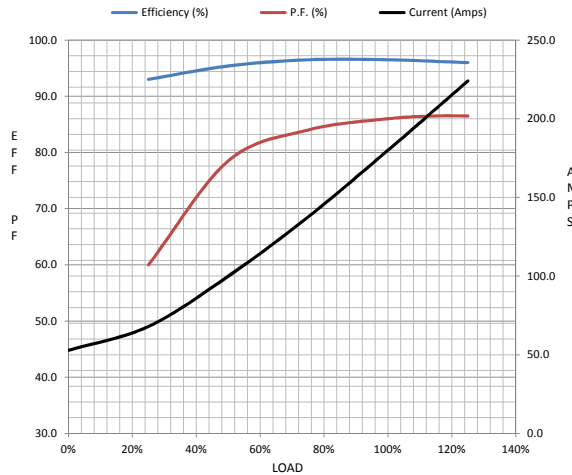

Enclosure	TEFC			
Construction	TFN			
Voltage	575 V			
Frequency	60 Hz			
Design	A			
LR Code letter	G			
Service Factor	1.15			
Temp Rise @ FL	70 ° C			
Duty	CONT			
Ambient	40 ° C			
Elevation	1,000 feet			
Rotor/Shaft wk²	77.0 Lb-Ft²			
Ref Wdg	T449447 NONE			
Sound Pressure @ 1M	75 dBA			
VFD Rating	CONSTANT 2:1			
Outline Dwg	B-SS515631-2875			
Conn. Diag	A-EE7300U			
Additional Specifications:				
0				
365THFS8036				
EQUIV CKT (OHMS / PHASE)				
R1	R2	X1	X2	Xm
0.0170	0.0110	0.1550	0.2290	5.4800

